

Mobile thermal printer

MPT-II Series

User Manual

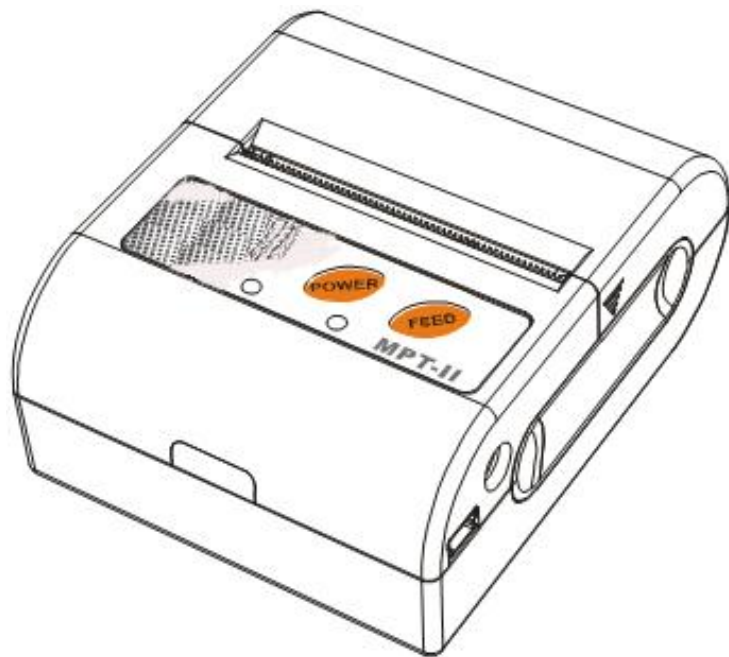

Content

Precautions	3
Chapter 1 Brief Introduction	5
1.1 Appearance	5
1.2 Accessories	5
Chapter 2 Specifications	6
2.1 Printing specifications	6
2.2 Physical specifications	6
2.3 Environment specifications	6
2.4 Other specifications.....	6
Chapter 3 Operation Methods	7
3.1 Preparation before using.....	7
3.1.1 Li-ion battery installation.....	7
3.1.2 Paper loading	7
3.2 Basic Function.....	8
3.2.1 Printer on	8
3.2.2 Printer off	8
3.2.3 Self-test	8
3.2.4 Paper loading	8
3.2.5 Battery Charging	8
3.3 Interfaces.....	8
3.3.1 Serial interface.....	8
3.3.2 Infrared ray (IR) & IrDA interface.....	8
3.3.3 Bluetooth	9
3.4 LED indicator and Buzzer definition.....	9
Chapter 4 Other information	9

Please read them care carefully before using mobile thermal printer.

Precautions

1. Safety Precautions

Be sure to use the specified battery and power source provided by our company. Connection to an improper power source may cause fire, explosion or damage to the printer.

Don't put the battery into the fire or water, don't disassemble or modify the battery, don't be short circuit, otherwise may result in injury or fire even explosion.

If the printer would not be used for a long time, be sure to take off the battery, otherwise the battery may leak liquid which is corrosive, if improper operation causes battery leak, and the liquid is spattered on the skin or clothes, please wash it with water, if spattered in the eyes, please rinse them with water thoroughly and see a doctor.

Please do not open the paper case cover when it is printing or just when printing is over, do not touch the print head with hand or body, overheat may cause scald.

2. Operation Precautions

Be sure not to print continuously over 1 meter, otherwise may cause damage to the print head.

Water or other liquid should not spill into the printer, also the printer should not be appeared in the rain, or else may cause printer damage.

Please do not open the paper case cover when it is printing, otherwise the printer may work improperly.

If print with serial interface, should not unplug the interface cable in the course of printing, or else some printing data may be lost.

When print in Ir or IrDA mode, be sure the Ir window of the host equipment face rightly the Ir window of the printer, the distance should be within the range of 50cm, and the angle should be within the range of 30°.

When print with Bluetooth interface, the communication distance should be within 10 meters, otherwise the printer doesn't print or prints rubbish codes.

Too high (50°C) or too low (-10°C) temperature and too high (80%) or too low (20%) relative humidity both effect the print quality.

The print paper in poor quality or stored for too long time also may reduce the print quality even damage the printer.

In the black mark detecting mode, the printer requires that the preprinted black mark is accordant with the black mark specifications (details please refer to 4.2), otherwise the black mark can not be detected correctly.

Be sure to use up the power of the battery before charge it, as it can ensure the using life of the battery.

3. Storage Precautions

The printer should be placed in such an environment that the temperature is between -20°C and 70°C, and the relative humidity is between 5% and 95%.

If the printer will be stored for a long time, please be sure to take out the battery, otherwise may damage the battery and printer.

Normal thermal paper can't be kept too long, if you need to keep the receipt for a long period, please choose long term effective thermal paper.

The print paper should be kept away from high temperature environment and point-blank sunshine.

4. Battery Safety Precautions

Be sure to carefully read the user manual before using the product.

Ignore the following instructions may cause battery overheating, fire, explosion, damage and / or performance, and reduced product life.

1) Do not allow water, sea water from entering or leaking into the battery inside. If the batteries internal safety device burn, when charging it, it may produce any abnormal current and / or voltage, and cause any abnormal chemical reaction, then may cause the battery overheating, fire and / or explosion.

2) Do not use or place the battery nearby the stove or other high temperature places. Excessive heat maybe damage the resin shell and / or the insulation materials, thereby cause short-circuit inside the battery, then the battery may be caused overheating, burning and / or explosion.

3) When charging, use a specified charger. Other conditions (high temperature, high pressure / high current, using the modified battery charger, etc.) excluded here may result in over-charging the battery and abnormal current and / or voltage, cause abnormal chemical reaction, and may cause the battery overheat, light and / or explosion.

4) Battery clearly marks with positive and negative. When connect the battery with the charger and / or printer, be sure to verify the correct battery orientation. Reverse insertion will cause the reverse charging and may cause abnormal chemical reaction, and then may cause the battery overheat, ignite, and / or explosion.

5) Do not make the battery contact with the power outlet and / or car cigarette lighter socket. This may cause high pressure and excessive current, and lead to the battery overheat, burning and / or explosion.

6) Do not heat the battery or put the battery into fire. This may melt insulation material and / or damage safety devices or safety equipment, then ignite electrolytic solution, and cause the battery overheat, burning and / or explosion.

7) Do not use the battery with contrary (+) and (-) Location. In the charging process, this will cause the reverse charging and may cause abnormal chemical reaction. During use, may appear unpredictable current exception, and cause the battery overheat, ignite, and / or explosion.

8) Do not make the battery (+) and (-) contact with any metal. Also, do not carry along or store batteries with metal objects, such as necklaces, hair clips and so on. Battery internal

short circuit may cause excessive current, and lead to the battery overheat, ignite, and / or explosion and the adjacent metal objects (necklaces, hairpins, etc.) may be overheating.

9) Do not throw or heavy attack the battery. If internal safety device of the batteries burn, the battery charging may cause any abnormal current and / or voltage, and abnormal chemical reaction, and lead to the battery overheat, ignite, and / or explosion.

Chapter 1 Brief Introduction

1.1 Appearance

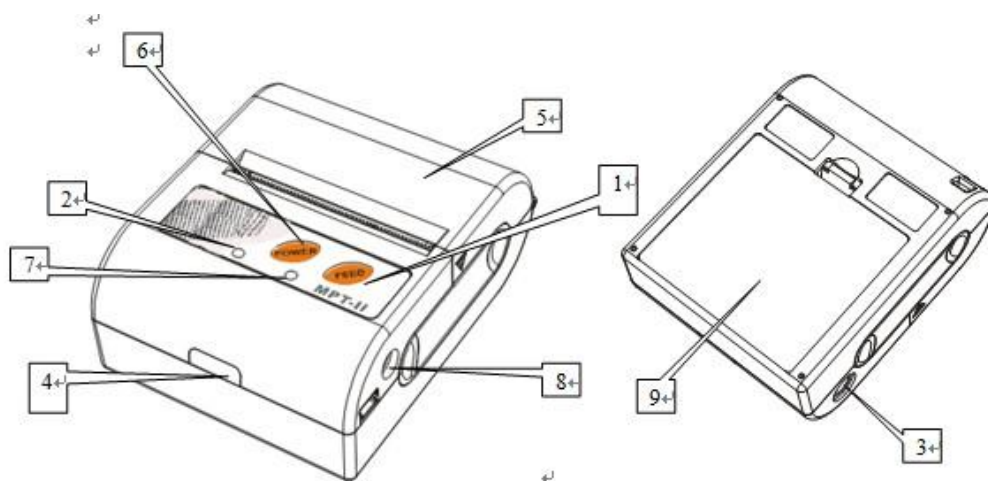

- 1) Feed button
- 2) Status indicator
- 3) RS232 serial socket
- 4) Infrared ray (IR) interface
- 5) Top cover
- 6) Power on/off
- 7) Charging indicator
- 8) Power input
- 9) Li-ion battery cover

Notice: two LED indicators are under button with different definition by red and blue two color.

1.2 Accessories

Standard accessories

Li-ion battery

Power cable

Power Adapter

Paper

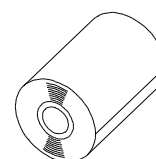
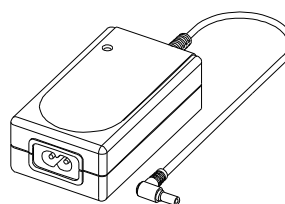
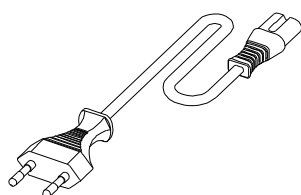
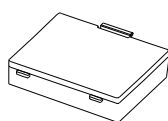

Optional accessories

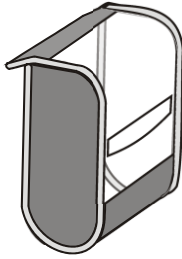

Leather case

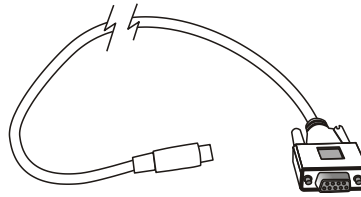

Serial interface cable

Chapter 2 Specifications

2.1 Printing specifications

- Printing method: Line thermal
- Paper width: 58mm
- Paper thickness: 60 ~ 80 μ m
- Valid printing width: 48 mm
- Resolution: 8 dot/mm (203 dpi)
- Dot /line: 384 dots
- Printing speed: 50-80 mm/s
- Printing content: GB18030 character set, ASCII characters, user defined characters, bar codes CODE39, EAN13, EAN8, CODABAR, CODE93, ITF, bitmaps.

2.2 Physical specifications

- Outer dimension: 92.5 x 75 x38mm/102.5x 75 x45mm
- Weight: 205g
- Paper Diameter: \leq 40mm
- Interface: Original IR(RAW_IR), IrDA (IrCOMM), RS232 serial, USB, Bluetooth varied with different models.

2.3 Environment specifications

- Operation temperature: -10 $^{\circ}$ C ~ 50 $^{\circ}$ C
- Operation humidity: 20% ~ 85%
- Storage temperature : -20 $^{\circ}$ C ~ 70 $^{\circ}$ C
- Storage humidity: 5% ~ 95%

2.4 Other specifications

- Paper loading method: drop-in easy loading
- Black mark detection: available (details please see 4.2 preprinting black mark specification).
- Paper out detection: when paper is out, the Mode indicator blinks, and the buzzer rings twice.
- Print commands: ESC/POS compatible command set.
- Power supply: 1500 mAh rechargeable li-ion battery.

- Low power alarm: when the battery is low, the power indicator blinks and the buzzer rings 2 times; and if the user doesn't charge, it will intervally beep to inform the user to charge.
- Battery full charge time: 2 to 4 hours.
- Battery duration: under 15% print density, at least 100 to 200 meters, under 25% print density, at least 100 meters, the standby time is over 15 days.

Chapter 3 Operation Methods

3.1 Preparation before using

3.1.1 Li-ion battery installation

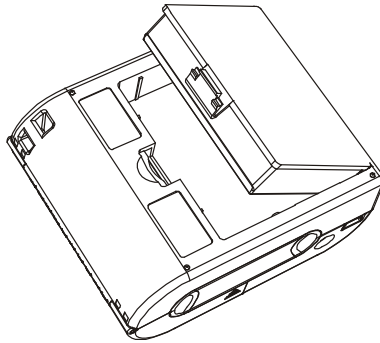

- 1) Refer to the picture, put the battery in the battery slot, please pay attention to the correct positive and negative.
- 2) Close the battery case.

3.1.2 Paper loading

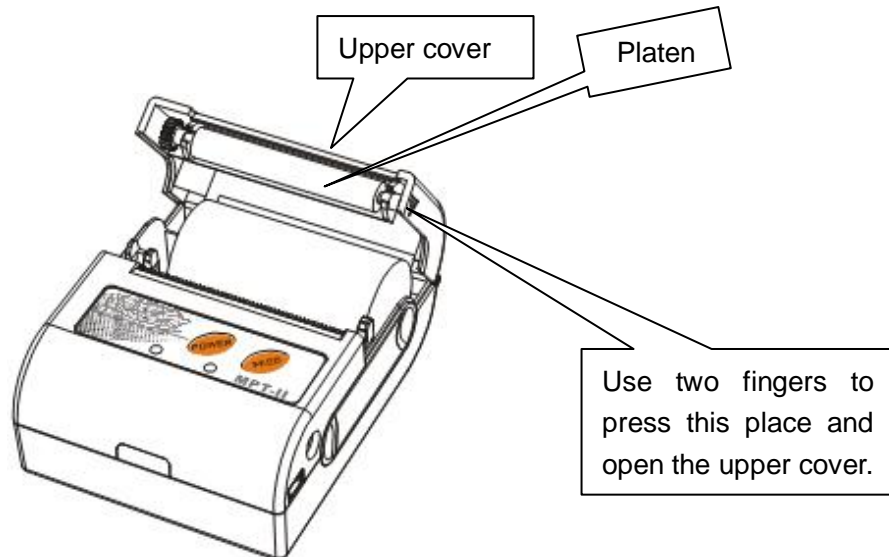

Operation methods:

- 1) Use two fingers to press the place showed in the picture and open the upper cover.
- 2) Put the paper into the paper case, pay attention to the direction of the paper. If loaded reversely, it won't print.
- 3) Pull paper out of paper case.
- 4) Make sure paper in the center then close upper cover.

3.2 Basic Function

3.2.1 Printer on

The printer is powered on by pressing the power button; the power indicator is on with red color whenever the printer is on.

Notice: when the batter is almost exhausted, the power indicator blinks with blue color, in this case, you must charge the battery by using the adaptor. The method of charging the battery, please refer to 3.2.5.

3.2.2 Printer off

The printer is off after hold down the power button for 2 seconds. All the indicators are off whenever the printer is off.

3.2.3 Self-test

The self-test checks the printer's current settings, status and whether the printer has any problems. Hold down the FEED button while press Power button about 3 seconds, the self-test begins.

The printer is ready to receive data as soon as it completes the self-test.

3.2.4 Paper loading

When standby, push FEED button, start feeding, will stop when feeding 50mm paper. User can change the feeding length according to software MPT-II_CONFIG in computer. Feeding length is 0mm, must push FEED button for continuous feeding, stop feeding once loosen button.

If there is the black mark (the detecting mark) recognized by printer on roll paper, printer will stop printing when meeting black mark. If feeding paper length is 0mm, feeding will not be effected by black marks.

3.2.5 Battery Charging

When li-ion battery runs out of power, blue LED indicator flash slowly and buzzer will give out warning. It will power off automatically when continues printing. If you want to go on, please charge it.

Charging method: Plug in socket (220V, 50Hz) with power adapter. Blue LED indicator continuously flashes while charging. When full, blue LED indicator will be bright.

When charging, printing is available.

3.3 Interfaces

3.3.1 Serial interface

Optical accessory DB-9 serial cable (other end is Mini din plug).

3.3.2 Infrared ray (IR) & IrDA interface

MPT-II can be connected to your host device through IR. RAW-IR and IrDA can't be available at the same time. Reset the printer if it is not the model you want.

When printing through RAW-IR and IrDA, make infrared ray of main device right towards to infrared ray window of printer, distance should be less than 50mm (varies with main

device), angle should be less than 30° .

3.3.3 Bluetooth

Hand terminal, notebook and other intelligence terminal drive to printer through Bluetooth.

Methods:

- 1.Add Bluetooth device through click Bluetooth icon with your mouse right button on Bluetooth control panel.
- 2.Find new device **MPT-II**.
- 3.Click 'next' and enter your password ' **0000** ', then finish.
- 4.The system will display interface added, one interface is output interface, the other input interface.

3.4 LED indicator and Buzzer definition

There are one buzzer and two LED indicators to indicate the printer status. LED indicators indicate current status and buzzer indicates the changes of status.

LED indicator (blue)	LED indicator (red)	Status	Buzzer
Flash quickly	Dark	Charging	
Flash slowly	Dark	Out of power	
Continuously bright	Dark	Charging end	
Dark	Bright continuously	Working	
Flash slowly	Flash slowly	Paper end	Warning
Dark	Flash slowly	Standby	

Chapter 4 Other information

4.1 Printer technical manual

Please refer to MPT-II technical manual.

4.2 Preprinted black mark specification

If user wants to locate receipt by detecting preprinted black mark, shall accord to the following specification for the black mark. Otherwise it may cause printer can't recognize the black mark.

Printing position: black mark shall preprint at the left side of receipt.

Width rang: $\geq 7\text{mm}$

Height: $4\text{mm} \leq \text{height} \leq 6\text{mm}$

Reflection rate to IR: $< 10\%$ (reflection rate to the black mark on paper $> 65\%$)

Hps: Hps indicates the distance from down edge of detecting mark from beginning line.

$0\text{mm} \leq \text{Hps} \leq 1\text{mm}$